

#Adulting Coloring Book



If adult coloring books told the real story.
Volume 1

By: Aaron Earls, Jonathan Howe,
Elizabeth Hyndman

Guess what?!?

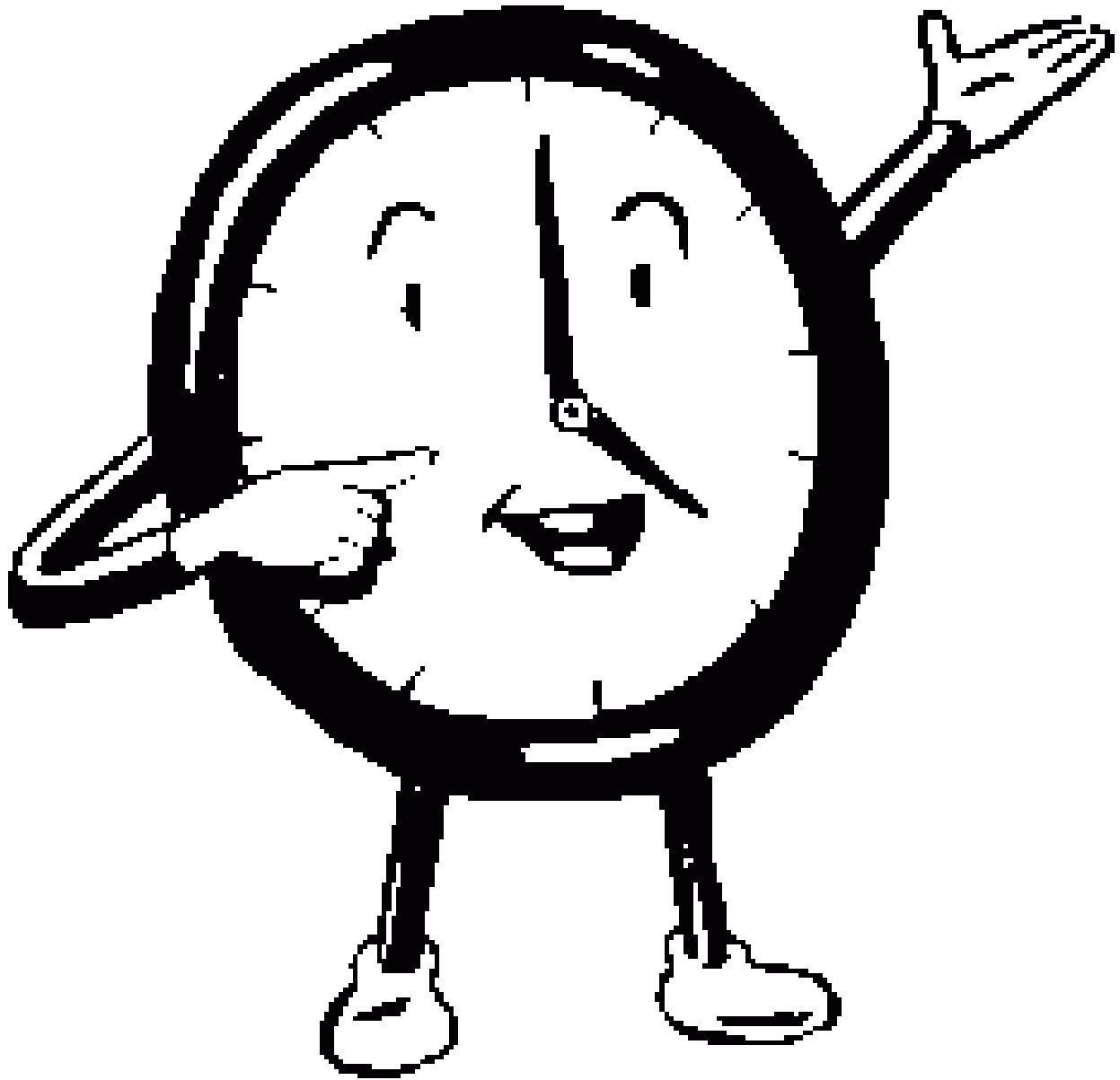

**5 o'clock is a time in
the morning, too.**

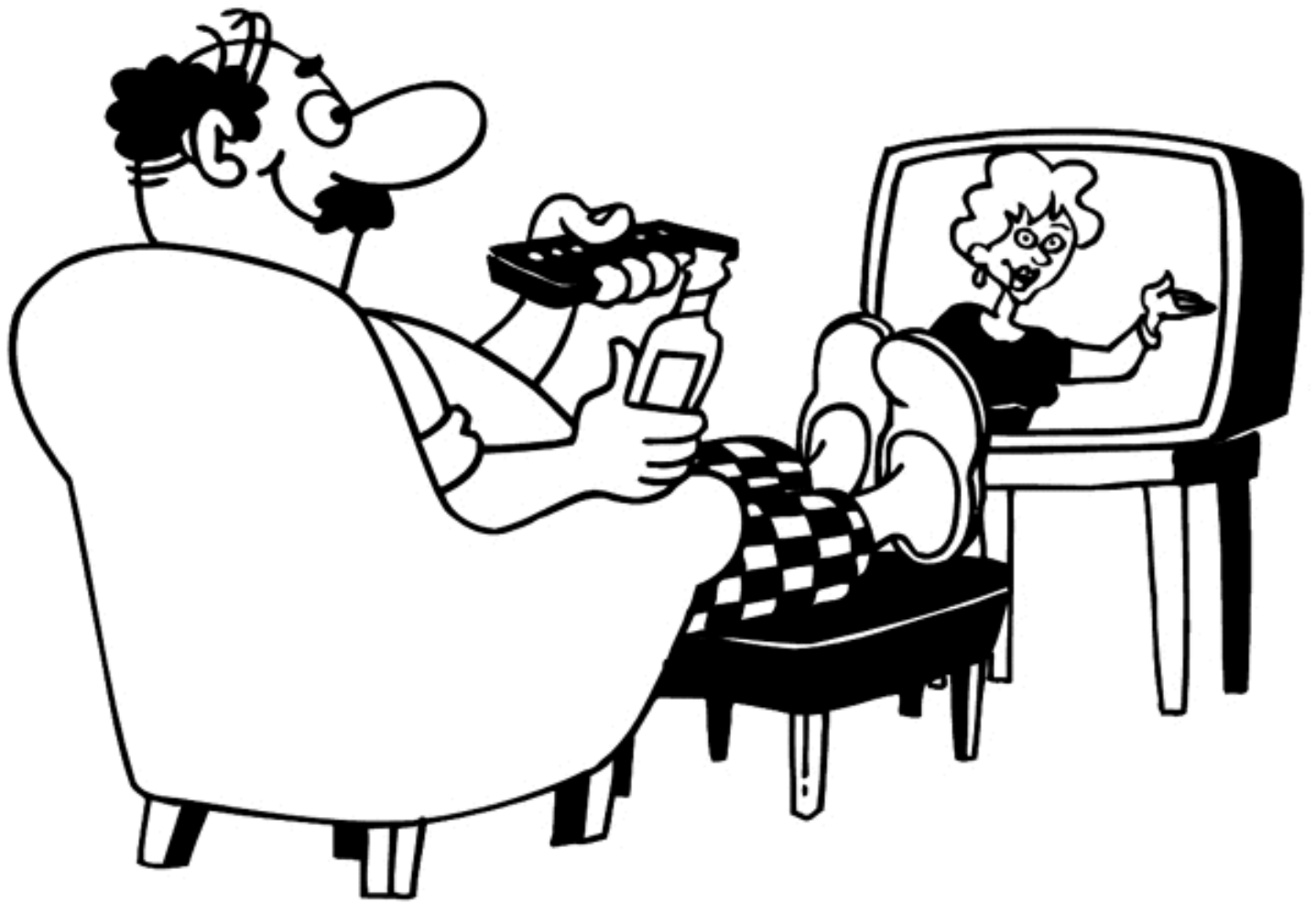

Marathons: They aren't just for runners now. Thanks to Netflix, even the out of shape can complete one.



**Join Bill and Debt's Not-So
Excellent Adventure.
(Bad puns are your only coping mechanism.)**



**Sometimes,
“college funds”
become new
transmissions.**

IKEA Instructions

1

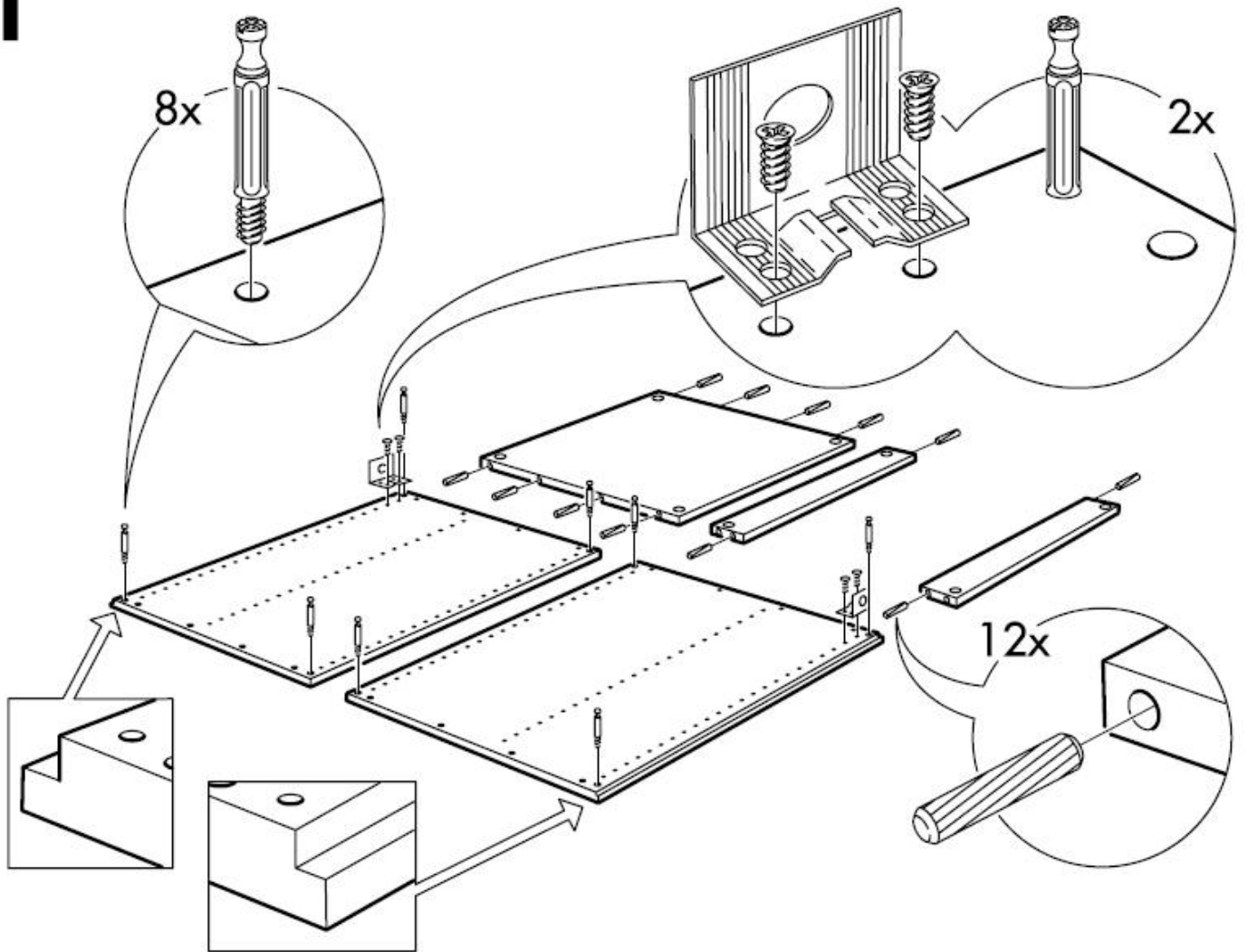

**No, there is no one to help
you figure them out.**

**Sometimes, popcorn
is a dinner food.**

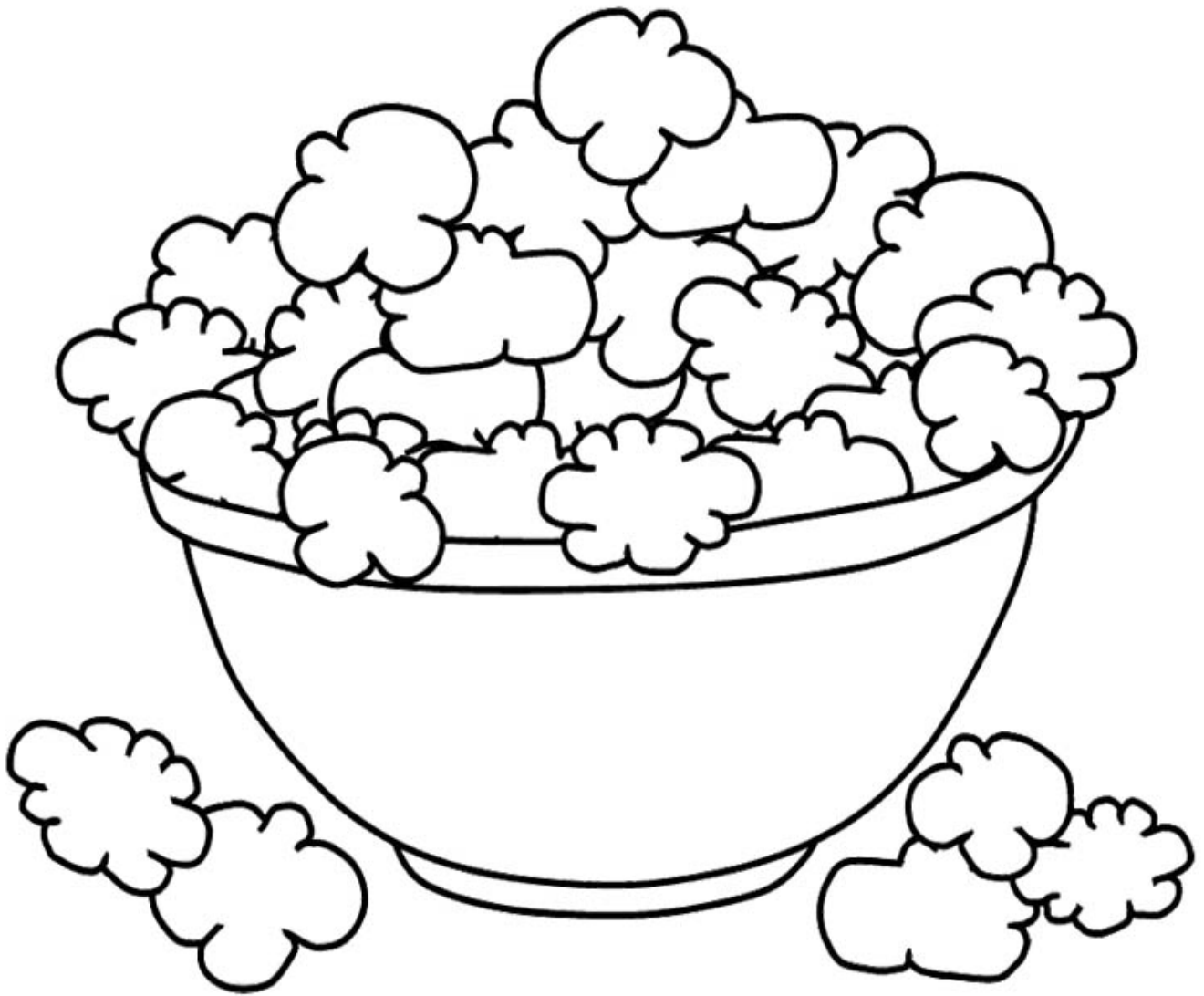

**No, that's not sad.
Why would you say that?**

“That cake’s not eating itself”

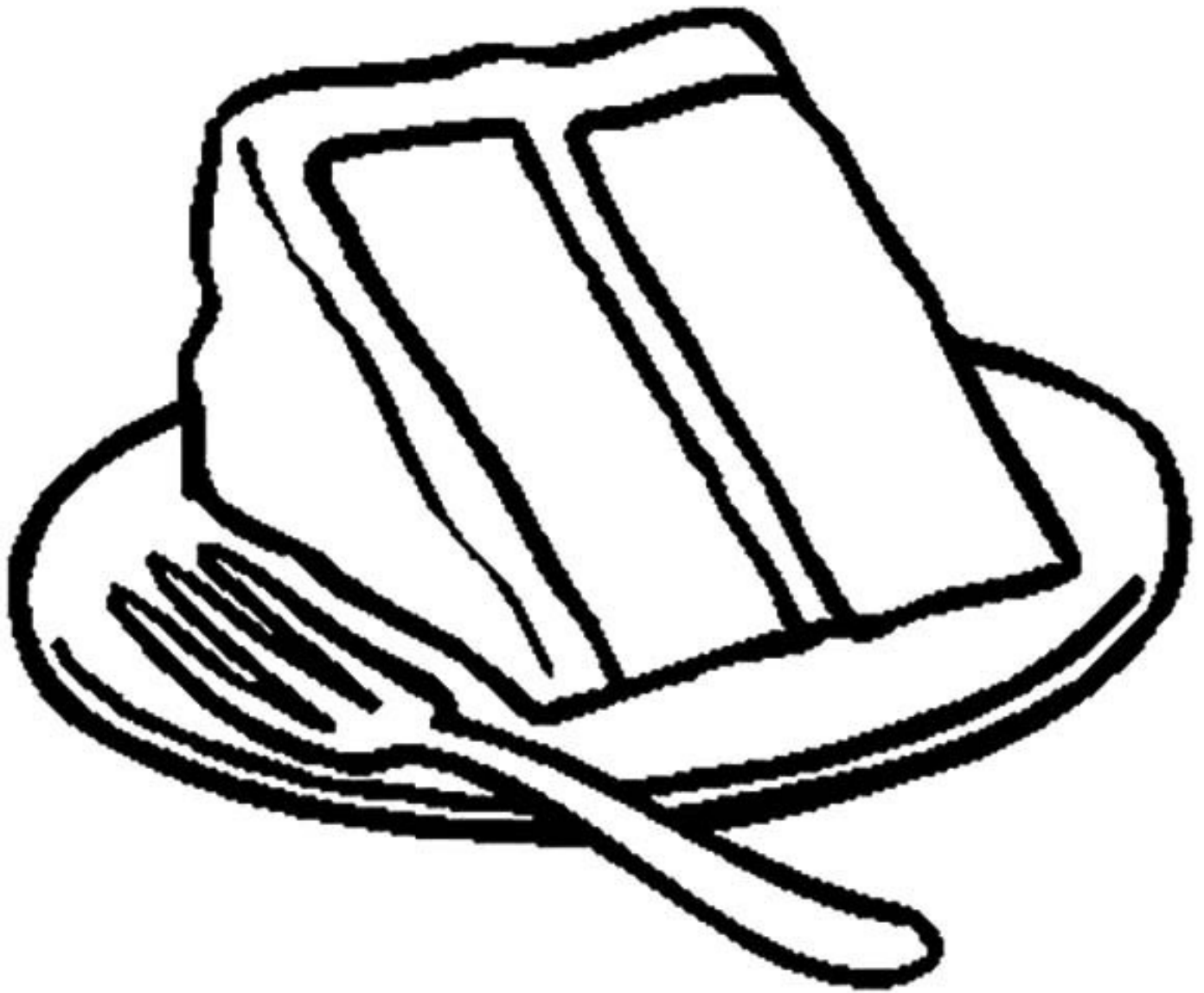

**is a perfectly good excuse
to eat an entire cake once
all the kids go to bed.**